

(Following Paper ID and Roll No. to be filled in your  
Answer Books)

Paper ID : 131406

Roll No.

--	--	--	--	--	--	--	--	--	--

**B.TECH.**

**Theory Examination (Semester-IV) 2015-16**

**ELECTRONIC CIRCUITS**

*Time : 3 Hours*

*Max. Marks : 100*

**Section-A**

**Q1. Attempt all parts. All parts carry equal marks.**

**(10×2=20)**

- (a) What do you mean by voltage follower circuit ? explain in brief.
- (b) Why Op Amp is rarely used in open loop configuration?
- (c) What is Barkhausen criteria for sinusoidal oscillations
- (d) Draw the current mirror circuit and write its output current equation.
- (e) State the properties of negative feedback.
- (f) What are the advantages of using an active load in differential amplifier circuit?
- (g) What are the types of feedback ?

- (h) Draw the Small signal  $\pi$  Model of BJT.
- (i) How does the slew rate effects Finite or Full power Band Width of Op Amp ?
- (j) An enhancement type NMOS transistor with  $V_t = 0.7V$  has its source terminal grounded and a 1.5V dc applied to the gate. In what region does the device operate for  $V_D = 0.9V$ .

### Section-B

**Q2. Attempt any five questions from this section. (10×5=50)**

- (a) Discuss the effect of finite loop gain on the performance of non-inverting OP-AMP.
- (b) A MOSFET is to operate at  $I_D = 1mA$  and is to have  $g_m = 1 mA/V$ . If  $K_n = 50\mu A/V^2$ . Find the required W/L ratio and the overdrive voltage.
- (c) Draw the high frequency model of MOSFET and derive an expression of  $f_H$ .
- (d) BJT transistor amplifier stage has  $R_E = R_C = 1.5k\Omega$ ,  $R_S = 6000\Omega$ ,  $R_L = 2k\Omega$  and transistor parameter as  $\beta = 100$  and  $r_\pi = 1k\Omega$ . Determine the value of  $C_{C1}$ ,  $C_{C2}$  and  $C_E$  needed to obtain  $f_L = 50Hz$  and also draw the circuit.
- (e) Explain the operation of BJT as a switch and as an amplifier.

- (f) Explain the Nonideal characteristics of MOS differential pair.
- (g) Draw a circuit diagram of Wein bridge oscillator and derive an expression of frequency of oscillation. Calculate the frequency of oscillation for given values of  $R_1=R_2=200\text{K}\Omega$ ,  $C_1=C_2=200\text{pF}$ .
- (h) Design the circuit shown in fig.1 so that transistor operates at  $I_D = 0.4\text{mA}$  and  $V_D = +0.5\text{V}$ . The NMOS transistor has  $V_t=0.7\text{V}$ ,  $\mu_n C_{ox} = 100\mu\text{A}/\text{V}^2$ ,  $L = 1\mu\text{m}$  and  $W = 32\mu\text{m}$ . Neglect the channel length modulation.

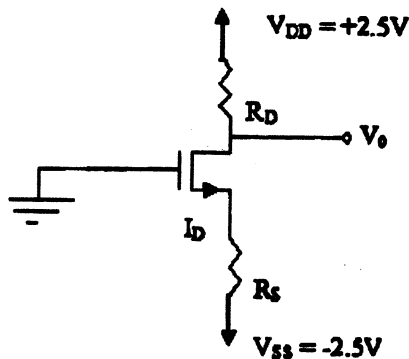

Fig. 1

### Section-C

**Note: Attempt any two questions from this section. (15×2=30)**

- Q3. (a) Draw Instrumentation Amplifier. How does it improve the performance parameters of an Op Amp?

(b) Define slew rate and show how it is related to full power bandwidth. An op-amp has a rated output voltage  $\pm 10V$  and slew of rate of  $1V/\mu S$ . What is its full power band width.

Q4. (a) Consider the common emitter circuit using a BJT having  $I_S=10^{-15}A$ . A collector resistance  $R_C=6.8 K\Omega$  and power supply  $V_{CC}=10V$ .

(i) Determine the value of bias voltage  $V_{BE}$  required to operate the transistor at  $V_{CE}=3.2V$ . what is the corresponding value of  $I_C$ .

(ii) Find the voltage gain  $A_v$  at this bias point.

(iii) If the input sine wave of  $5mA$  peak amplitude is superimposed one  $V_{BE}$ . Find the amplitude of output sine wave signal.

(b) Draw the circuit for CB amplifier and find expression for short circuit gain.

Q5. (a) Draw the T equivalent circuits of common source amplifier with a source resistance and obtain the expressions for  $R_{in}$ ,  $R_{out}$ , and  $G_v$ .

(b) An inverting amplifier has feedback resistor  $R_2=500K\Omega$  and  $R_1=5K\Omega$ . Find the amplifier circuit voltage gain, input resistance and output resistance. Also find the output voltage and input current if the input voltage is given as .1 volts. Assume the OP-AMP to be an ideal one.