

(Following Paper ID and Roll No. to be filled in your Answer Book)

PAPER ID : 2481

Roll No.

--	--	--	--	--	--	--	--	--	--

B. Tech.

(SEM. VI) THEORY EXAMINATION 2010-11

ANALOG SIGNAL PROCESSING

Time : 2 Hours

Total Marks : 50

Note : Attempt **all** questions. All questions carry equal marks.

Assume any data missing suitably.

1. Attempt any **two** questions : (7×2=14)

- (a) Design an integrator circuit having an input impedance of $1\text{ k}\Omega$, time constant = 1 ms . What is the gain at $\omega_0 = 100\text{ rad/sec}$ and $\omega_0 = 1000\text{ rad/sec}$. At what frequency the gain becomes unity?
- (b) Draw the circuit diagram of a non-inverting differentiator using one op-amp. Derive its transfer function and draw its frequency response and phase response.
- (c) Design the circuit shown in Figure-1 using the equation $-V_0 = 6V_1 + 4V_2 - 9V_3$. Using the concept of 2-port network explain the negative impedance converter (NIC),

positive impedance converter (PIC), negative impedance inverter (NII), positive impedance inverter (PII)

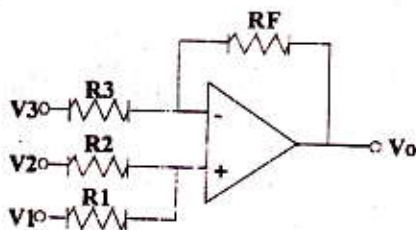

Figure-1

2. Attempt any two questions : (6×2=12)

- Explain the operation of the circuit shown in Figure-2 and calculate the expression for output voltage V_{o1} and V_{o2} . Also draw the nature of output waveforms for V_{o1} and V_{o2} .
- Explain the operation of a precision AC/DC converter with the help of a neatly labeled circuit diagram.
- With the help of a neatly labeled circuit diagram explain the operation of an rms-to-dc converter and an amplitude demodulator.

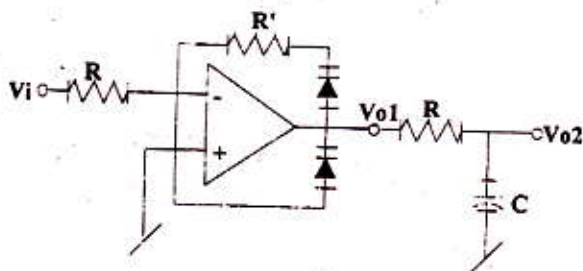

Figure-2

3. Attempt any **two** questions : (6×2=12)

- (a) Design the circuit of a logarithmic multiplier which gives an output voltage given by the equation $-V_o \propto V_{i1} \cdot V_{i2}$.
- (b) Design a circuit using analog multiplier which produces and output given by the equation $-V_o \propto (V_{i1} \cdot V_{i2})^{1/2}$.
- (c) Explain the operation of a voltage limiter circuit with the help of a neatly labeled circuit diagram.

4. Attempt any **two** questions : (6×2=12)

- (a) For the circuit diagram shown in Figure-3 derive the expression for V_o/V_i . Select the type of admittances either resistive or capacitive such that the circuit realizes a low-

pass filter, high-pass filter and band-stop filter. Find the filter parameters.

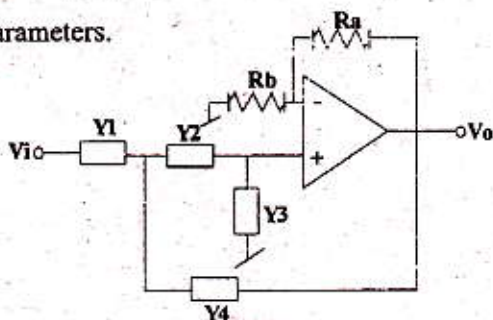

Figure-3

- (b) For the circuit shown in Figure-4 obtain the transfer function for low-pass filter and band-pass filter. What additional hardware is required to realize high-pass, notch and all-pass filters ?

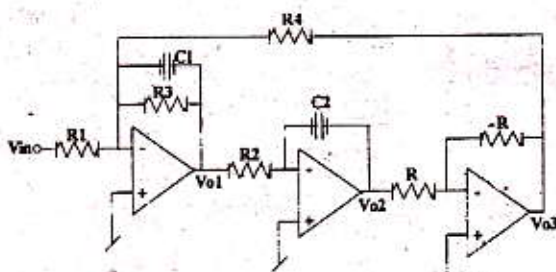

Figure-4

- (c) Using OTAs draw the circuit which realizes a grounded inductor and floating inductor and derive the expression for equivalent inductances.