



Roll No:

--	--	--	--	--	--	--	--	--	--	--	--	--	--	--

**BTECH**  
**(SEM III) THEORY EXAMINATION 2023-24**  
**NETWORK ANALYSIS AND SYNTHESIS**

TIME: 3HRS

M.MARKS: 70

**Note: 1.** Attempt all Sections. If require any missing data; then choose suitably.

**SECTION A**

**1. Attempt all questions in brief.**

**2 x 7 = 14**

Q no.	Question	Marks	CO
a.	What is node analysis, and how is it different from mesh analysis?	2	1
b.	Explain the significance of reactance in network analysis.	2	1
c.	State the superposition theorem.	2	2
d.	Define reciprocity theorem.	2	2
e.	Define singularity functions.	2	3
f.	Explain the concept of poles and zeros in network functions.	2	4
g.	What are the characteristics of band-reject filters?	2	5

**SECTION B**

**2. Attempt any three of the following:**

**7 x 3 = 21**

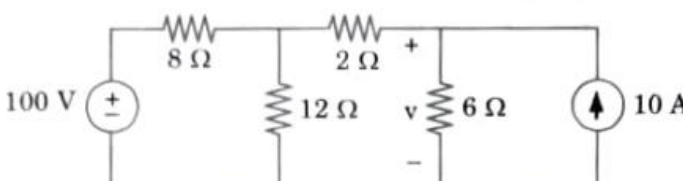
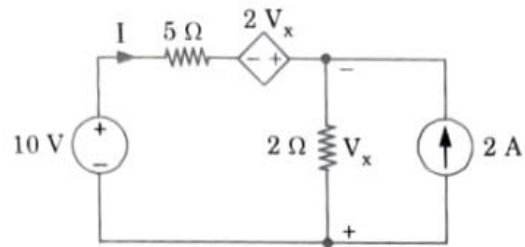
Q no.	Question	Marks	CO
a.	For the circuit shown in Fig., determine the voltage using nodal analysis. 	7	1
b.	Calculate the current I shown in Fig. by using superposition theorem. 	7	2
c.	Explain step response of series RC circuit.	7	3
d.	Describe the concept of symmetry in two-port networks. Discuss how symmetry affects the port parameters and overall behavior of the network.	7	4
e.	State and prove convolution theorem.	7	5

**SECTION C**

**3. Attempt any one part of the following:**

**7 x 1 = 7**

Q no.	Question	Marks	CO
a.	Write the mesh current equations in the circuit shown in Fig., and determine the currents.	7	1



Roll No: 

--	--	--	--	--	--	--	--	--	--	--	--	--	--	--	--	--	--	--

**BTECH**  
**(SEM III) THEORY EXAMINATION 2023-24**  
**NETWORK ANALYSIS AND SYNTHESIS**

TIME: 3HRS

M.MARKS: 70

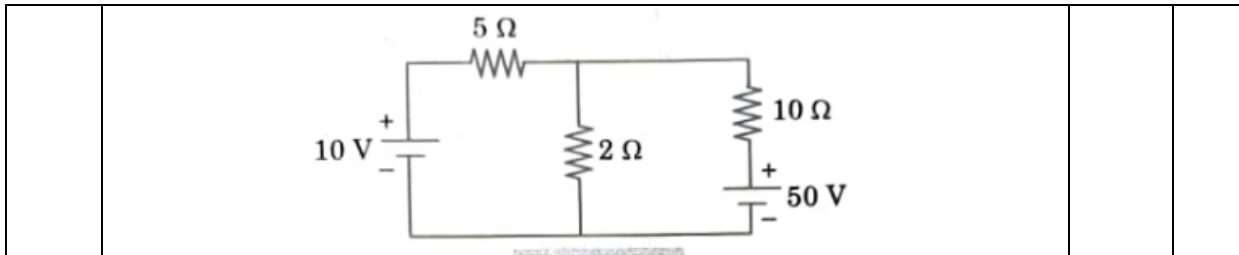

b. What do you mean by "duality of graph of the network"? Also mention its utilities and drawbacks. 7    1

**4. Attempt any one part of the following: 7 x 1 = 7**

Q no.	Question	Marks	CO
a.	State reciprocity theorem in AC network.	7	2
b.	Find the Norton equivalent circuit of the circuit in Fig. at terminals a-b	7	2

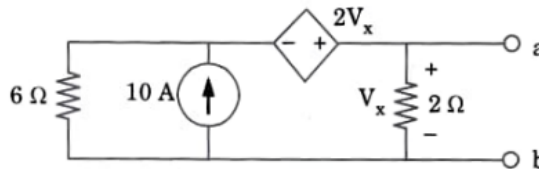

**5. Attempt any one part of the following: 7 x 1 = 7**

Q no.	Question	Marks	CO
a.	Write the Laplace transforms of: i. Unit impulse ii. Unit step iii. Unit ramp and iv. Parabolic functions.	7	3
b.	What is inverse Laplace transform? Calculate inverse Laplace Transform of $e^{-5s} U(s)$ .	7	3

**6. Attempt any one part of the following: 7 x 1 = 7**

Q no.	Question	Marks	CO
a.	Explain the concept of cascading two-port networks. Discuss any limitations or issues that may arise when cascading networks.	7	4
b.	Determine the y and z parameters for a two-port network.	7	4

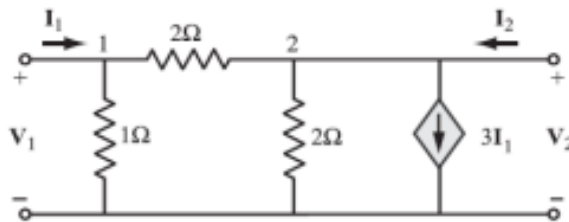

**7. Attempt any one part of the following: 7 x 1 = 7**

Q no.	Question	Marks	CO
a.	Explain quality factor. Also give relationship between bandwidth and quality factor of the circuit.	7	5
b.	Derive an expression for parallel resonance and mention its salient features.	7	5