



Roll No:

--	--	--	--	--	--	--	--	--	--	--	--	--	--	--	--	--	--	--	--

**BTECH**  
**(SEM IV) THEORY EXAMINATION 2024-25**  
**ANALOG CIRCUITS**

**TIME: 3 HRS**

**M.MARKS: 70**

**Note:** Attempt all Sections. In case of any missing data; choose suitably.

**SECTION A**

**1. Attempt all questions in brief.**

**02 x 7 = 14**

Q no.	Question	CO	Level
a.	Define Transconductance and Trans-resistance Amplifiers.	1	K1
b.	Draw T-model equivalent circuit of NPN transistor.	1	K1
c.	Explain Bakhausen criterion.	3	K2
d.	What is the principle of crystal oscillator?	3	K1
e.	Define minimum sustainable voltage and maximum usable load of a Current mirror Circuits	4	K1
f.	What do you mean by slew rate and CMRR of an Op-Amp?	5	K2
g.	A BJT having $\beta = 100$ is biased at a dc collector current of 1 mA. Find the value of $g_m$ and $r_e$ .	2	K3

**SECTION B**

**2. Attempt any three of the following:**

**07 x 3 = 21**

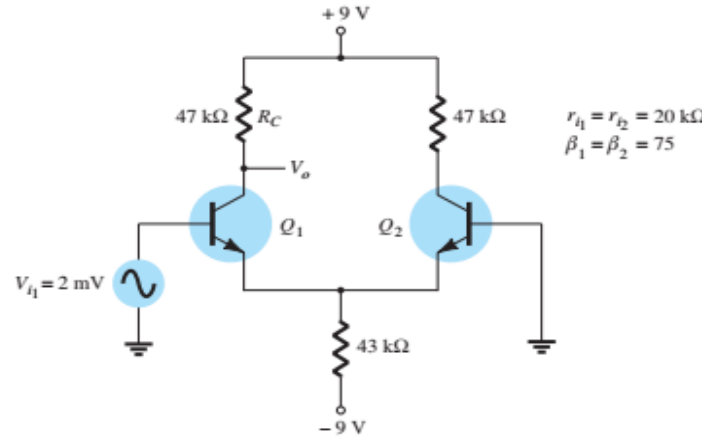
Q no.	Question	CO	Level
a.	Draw the circuit diagram of single stage CE amplifier using hybrid- $\pi$ model and find out the expression of $i_c$ , $g_m$ and $i_b$ .	1	K3
b.	Design a shunt-series feedback amplifier and calculate expressions for $A_f$ , $R_{of}$ and $R_{if}$ .	2	K6
c.	Explain the working of Wien Bridge Oscillator. Derive the expression for feedback factor ( $\beta$ ) and frequency ( $f$ ).	3	K3
d.	Calculate the output voltages of the given differential amplifier. 	4	K3
e.	Design the following circuits using op-Amp: i) Unity gain amplifier ii) Integrator circuit	5	K6



Roll No:

--	--	--	--	--	--	--	--	--	--	--	--	--	--	--	--	--	--	--	--

**BTECH**  
**(SEM IV) THEORY EXAMINATION 2024-25**  
**ANALOG CIRCUITS**

**TIME: 3 HRS**

**M.MARKS: 70**

**SECTION C**

**3. Attempt any one part of the following: 07 x 1 = 07**

Q no.	Question	CO	Level
a.	Draw the circuit diagram of single stage CC amplifier using T-model and find out the expression of voltage gain.	1	K3
b.	Show the effect of multi stage amplification in low and high frequency applications.	1	K6

**4. Attempt any one part of the following: 07 x 1 = 07**

Q no.	Question	CO	Level
a.	Draw the high frequency model of MOSFET and drive an expression of $f_H$ .	2	K3
b.	Design a series-series feedback amplifier and calculate expressions for $A_f$ , $R_{of}$ and $R_{if}$ .	2	K6

**5. Attempt any one part of the following: 07 x 1 = 07**

Q no.	Question	CO	Level
a.	Draw the circuit of an RC phase shift oscillator using op-amp and derive frequency and condition of oscillation for RC phase shift oscillator.	3	K3
b.	For the Hartley Oscillator, derive an expression for the frequency of oscillation.	3	K3

**6. Attempt any one part of the following: 07 x 1 = 07**

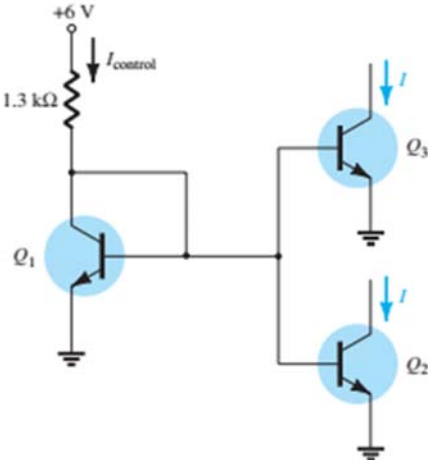
Q no.	Question	CO	Level
a.	Draw the basic structure of differential amplifier and calculation the differential gain, common mode gain and CMRR.	4	K3
b.	Calculate the current $I$ through each of the transistor $Q_2$ and $Q_3$ in the given circuit. 	4	K3



Roll No:

--	--	--	--	--	--	--	--	--	--	--	--	--	--	--	--	--	--	--	--

**BTECH**  
**(SEM IV) THEORY EXAMINATION 2024-25**  
**ANALOG CIRCUITS**

**TIME: 3 HRS**

**M.MARKS: 70**

7. Attempt any *one* part of the following:

07 x 1 = 07

Q no.	Question	CO	Level
a.	Explain the effect of finite loop gain and bandwidth on the performance of Op-Amp. Also define input offset voltage and input offset current.	5	K2
b.	Find out the output voltage ( $V_o$ ) of the following circuit using ideal Op-Amp.	5	K3

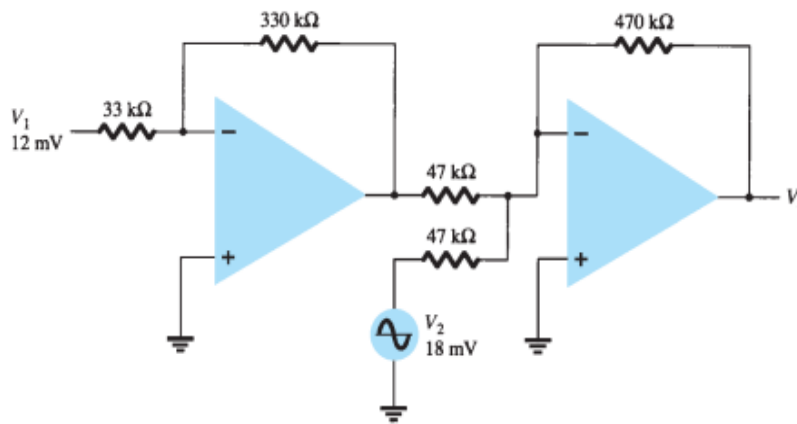

QP25  
| 24-Jul-2025 1:31:07 PM | 122.185.51.242