



Roll No:

--	--	--	--	--	--	--	--	--	--	--	--	--	--	--	--	--	--	--	--

BTECH
(SEM I) THEORY EXAMINATION 2023-24
BASIC ELECTRICAL ENGINEERING

TIME: 3HRS

M.MARKS: 100

Note: 1. Attempt all Sections. If require any missing data; then choose suitably.

SECTION A

1. Attempt all questions in brief.

Q no.	Question	Marks	CO
a.	Give the statement of thevenin's theorem.	2	1
b.	Explain active and passive elements with examples.	2	1
c.	What is the rms and average value of sinusoidal voltage.	2	2
d.	Define resonance in series RLC circuit.	2	2
e.	Explain the types of losses in transformer.	2	3
f.	What are ferromagnetic materials. Give their properties.	2	3
g.	Why single phase induction motor is not self starting.	2	4
h.	What are the starting methods of synchronous motor.	2	4
i.	Explain switchgear and its need in electrical systems?	2	5
j.	Explain the function of SFU?	2	5

SECTION B

2. Attempt any three of the following:

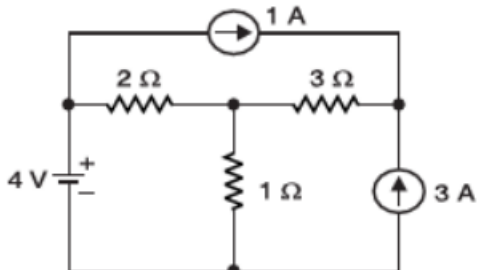
Q no.	Question	Marks	CO
a.	Using mesh analysis, find current in $2\ \Omega$ resistor in the circuit shown in figure below: 	10	1
b.	Derive the Bandwidth, Lower half power frequency, Upper half power frequency of series resonant RLC circuit.	10	2
c.	(i) Derive the emf equation of a transformer. (ii) Draw the phasor diagram of ideal transformer at no load condition.	10	3
d.	Derive the emf equation of DC machine. Also give the types of DC generators.	10	4
e.	Describe the operating principle of MCB and ELCB in details with necessary circuit diagrams.	10	5

SECTION C

3. Attempt any one part of the following:

Q no.	Question	Marks	CO
a.	Using thevenin's theorem find the current in $20\ \Omega$ resistance in the circuit.	10	1



Roll No:

--	--	--	--	--	--	--	--	--	--

BTECH
(SEM I) THEORY EXAMINATION 2023-24
BASIC ELECTRICAL ENGINEERING

TIME: 3HRS

M.MARKS: 100

b.	<p>Find the current in 8 Ω resistance using superposition theorem.</p>	10	1

4. Attempt any one part of the following:

Q no.	Question	Marks	CO
a.	<p>Consider an electrical circuit shown in Figure. Determine (i) the current and power consumed in each branch (ii) the supply current and power factor.</p>	10	2
b.	<p>Derive the relation between line and phase voltages for a delta-connected 3-φ balanced system. A balanced star-connected load of (10+j8) Ω/phase is connected to 3-φ, 440 V supply. Calculate line current, power factor, and power drawn by it.</p>	10	2

5. Attempt any one part of the following:

Q no.	Question	Marks	CO
a.	<p>Explain the working of a single, phase transformer with suitable diagram. Draw the complete equivalent circuit model of a real transformer.</p>	10	3
b.	<p>A 50 kVA, 2000/200V transformer has full load copper & iron losses of 1.8 kW & 1.5 kW respectively. Figure out:</p> <ul style="list-style-type: none"> (i) The efficiency at half load & at unity power factor. (ii) The efficiency at full load & at 0.8 power factor lagging. (iii) Maximum efficiency and the load corresponding to max. efficiency 	10	3



Roll No:

--	--	--	--	--	--	--	--	--	--	--	--	--	--	--	--	--	--	--	--

BTECH
(SEM I) THEORY EXAMINATION 2023-24
BASIC ELECTRICAL ENGINEERING

TIME: 3HRS

M.MARKS: 100

6. Attempt any one part of the following:

Q no.	Question	Marks	CO
a.	An 8-pole, 400V shunt motor has 960 wave connected armature conductors. The full load armature current is 40A and flux per pole is 0.02Wb. The armature resistance is 0.1Ω and the contact drop is 1V per brush. Calculate the full load speed of the motor.	10	4
b.	Draw and explain Torque-slip characteristics of 3-phase induction motor. A 3-phase, 4 pole induction motor is supplied from 3-phase, 50 Hz ac supply. Determine: Synchronous speed, rotor speed when slip is 4% and rotor frequency.	10	4

7. Attempt any one part of the following:

Q no.	Question	Marks	CO
a.	(i) Write short notes on cables (ii) Write short notes on types of batteries	10	5
b.	Explain the need of earthing of electrical equipment. What are the different methods of earthing.	10	5

QP24DP2_143

/ 15-03-2024 08:57:47 | 182.71.247.82