



Roll No:

--	--	--	--	--	--	--	--	--	--	--	--	--	--	--

**BTECH**  
**(SEM VII) THEORY EXAMINATION 2023-24**  
**COMPUTER AIDED DESIGN & MANUFACTURING**

TIME: 3 HRS

M.MARKS: 70

**Note:** Attempt all Sections. If require any missing data; then choose suitably.

**SECTION A**

1. Attempt *all* questions in brief.

2 x 7 = 14

a.	What are the essential requirements of CAD?
b.	What is the purpose of a view port in computer graphics?
c.	Define the purpose of GKS in computer graphics.
d.	Write down the basic steps for finite element solution process.
e.	What is NC in CAM?
f.	Explain the significance of end effectors in robotics.
g.	Define one advantage of using rapid prototyping techniques in the manufacturing process.

**SECTION B**

2. Attempt any *three* of the following:

7 x 3 = 21

a.	Find the transformed coordinates of a triangle having vertices A (4, 1), B (7, 1) and C (7, 3) subjected to reflection through the line $2y = x$ .
b.	What is graphics software? Also explain what are the basic rules that are considered before designing graphics software?
c.	What is an Insert used in CNC? Which one of these three main machining parameters has the largest impact on insert tool life? Discuss the ISO designation for turning inserts.
d.	Describe the key components of a robot's control system and their roles.
e.	Describe the basic principles of rapid prototyping and how it contributes to the efficiency of product development.

**SECTION C**

3. Attempt any *one* part of the following:

7 x 1 = 7

a.	Generate parametric equation of a planer Bezier curve defined by the four-control points $P_0 (1, 2)$ , $P_1 (3, 4)$ , $P_2 (6, -6)$ and $P_3 (9, 7)$ and plot them.
b.	Construct the following solid model of object with a hole on one plate as shown in figure using CSG standard primitives and also to develop the history tree.

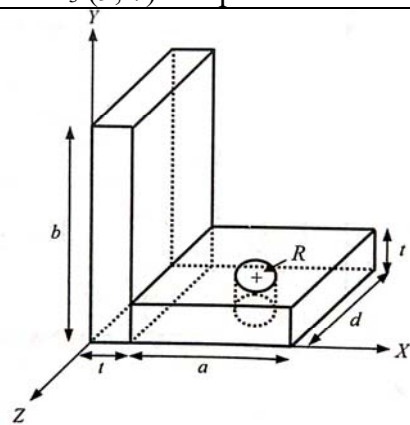



Roll No:

--	--	--	--	--	--	--	--	--	--	--	--	--	--	--	--

**BTECH**  
**(SEM VII) THEORY EXAMINATION 2023-24**  
**COMPUTER AIDED DESIGN & MANUFACTURING**

TIME: 3 HRS

M.MARKS: 70

4. Attempt any *one* part of the following:

7 x 1 = 7

a.	Explain the process of mesh generation in Finite Element Modelling. Discuss the mesh requirements for accurate simulation.
b.	Define the following terms related to FEM: (i) Global stiffness matrix (ii) Pre-processors and post-processors

5. Attempt any *one* part of the following:

7 x 1 = 7

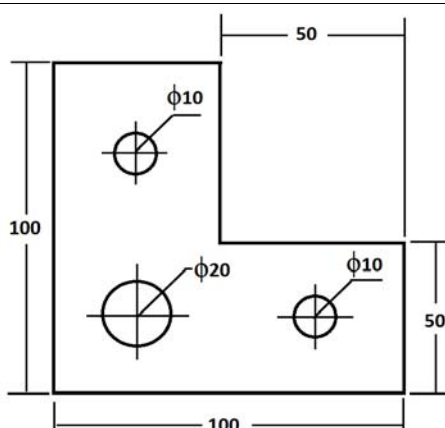
a.	 <p>Write NC part program for the machined component of thickness 12 mm to be to drill all the holes as shown in figure. All dimensions are given in mm. Assume speed = 750 RPM and feed = 150 mm/min.</p>
b.	Describe the various types of material handling in a CAM environment. Discuss the use of AGVS, AS/RS, and quantitative analysis of assembly systems.

6. Attempt any *one* part of the following:

7 x 1 = 7

a.	Discuss the importance of Machine Vision in robotics. Provide examples of its applications in assembly processes.
b.	Explain the concept of Capacity Planning in the context of ERP. How does effective capacity planning optimize manufacturing processes?

7. Attempt any *one* part of the following:

7 x 1 = 7

a.	Explain the role of Group Technology (GT) and Just-In-Time (JIT) in the context of Flexible Manufacturing Systems (FMS).
b.	Explain the basic principles of Laminated Object Manufacturing (LOM). Compare it with Fusion Deposition Modelling (FDM) in terms of advantages and limitations.